

Portable Compressors

Mobilair™ M270



Tough, dependable unit

The Mobilair™ M270 are versatile units suited for a number of applications including road construction, mining, and back-up industrial plant air. Units are also well suited for rental houses and railroads.

The M270 offers a wide array of features that make them very user-friendly. Units come standard with an easy-to-read control panel that is well protected and visible from the outside. The fuel tank has a large filler neck with overflow protection for safe, easy filling. A height adjustable tow bar makes transporting

the units easy. Torsion bar suspension and oversized tires provide superior road handling.

Unsurpassed durability and quietness

The M270's heavy-duty steel chassis and fully galvanized enclosure are built to withstand even the harshest conditions. Both the enclosure and solid steel flooring protect the motor, airend, and critical components from dirt and water. The enclosure is also super soundproofed and provides extremely quiet operation.

Capacity:

950 cfm

Pressures:

from 70 to 205 psig

Standard Features:

- Sigma Profile rotary screw airend produces more air with less fuel consumption
- Heavy duty steel chassis
- Fully galvanized enclosure
- Access doors allows easy access to all maintenance points
- Solid steel floor for low noise and structural integrity
- Torsion bar suspension system for superior road handling and increased ground clearance
- Lockable access doors and instrument panel
- Lighting and bumper kit
- Heavy duty, liquid cooled, turbo-charged diesel engine complies with Tier 3 emissions standards

Optional Features:

- Pressures up to 205 psig
- Filtration packages and aftercoolers
- Complete line of air tools
- Lubricators and separators
- Skid mounted units

- 1** Heavy duty bumpers and lighting kits are standard
- 2** High capacity cold start battery ensures reliable operation even under severe working conditions
- 3** Heavy duty, liquid cooled, turbo-charged diesel engine complies with Tier 3 emissions standards
- 4** Lifting eye for simple handling
- 5** 2 different axle configurations provide options for transport (twin axle shown)
- 6** Rigid pipes incorporate flexible connections and are leak proof
- 7** 4 micron, 2 stage compressor inlet filter with maintenance indicator
- 8** 10 micron spin-on oil filter with integral thermostatic valve
- 9** Sigma Profile rotary screw airend produces more air with less fuel consumption
- 10** Tow bar
- 11** Height adjustable hitch

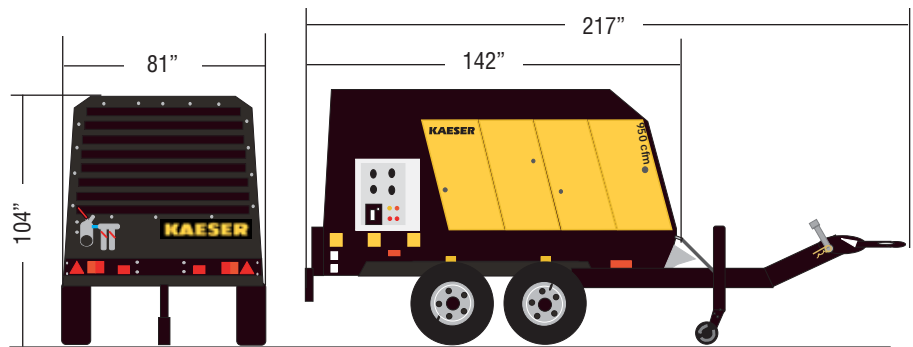
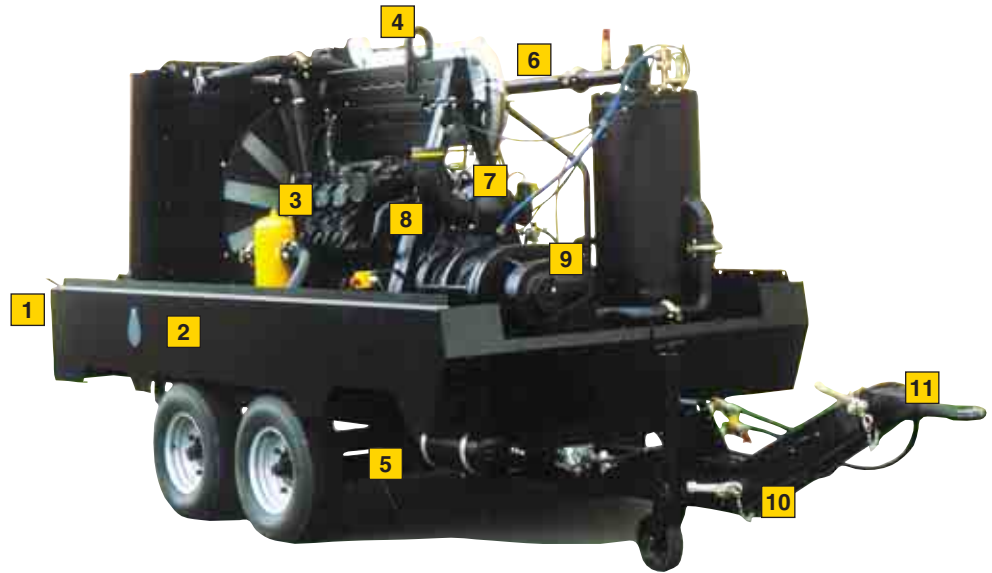

Specifications

Compressor		Diesel Engine		Package	
Free air delivery (cfm)	950	Make	Mercedes Benz OM501LA	Fuel tank capacity (gal)	146
Working pressure (psig)	100	Power at full load (hp)	313	Weight, dry (lb.)	9634
		Full load Speed (rpm)	1700	Sound level max.	76 dB(A) at 23 ft.
		Off load running speed (rpm)	1200		

Specifications are subject to change without notice.

KAESER COMPRESSORS

Built for a lifetime.™

Corporate Headquarters:
P.O. Box 946
Fredericksburg, Virginia 22404
Phone 540-898-5500
Fax 540-898-5520
www.kaeser.com

Certified Management Systems



The Air Systems Specialist

With over 85 years of experience, Kaeser is the air systems specialist. Our extensive 100,000 square foot facility allows us to provide unequalled product availability. With service centers nationwide and our 24-hour emergency parts guarantee, Kaeser customers can rely on the best after-sales support in the industry. Kaeser stands committed to providing the highest quality air system for your specific compressed air needs.