

83G (GALVANIZED) AND 83S (STAINLESS STEEL) TANKS Large Tank - Up To 9.8 Gallons

IMPORTANT: Read and follow all instructions and **SAFETY PRECAUTIONS** before using this equipment. Retain for future reference.

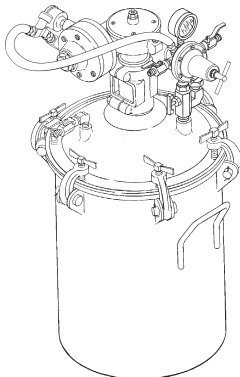

DESCRIPTION

Binks pressure feed tanks are intended for use as a pressure container to supply material at a constant preset pressure up to a maximum of 110 psi. The tanks are built to ASME specifications. These pressure tanks are also certified for vacuum operation.

WARNING

(Galvanized Tanks)

Halogenated hydrocarbon solvents - for example: 1,1,1, - trichloroethane and methylene chloride - can chemically react with aluminum parts and components and cause an explosion hazard. These solvents will also corrode the galvanized tank coating. Read the label or data sheet for the material. Do not use materials containing these solvents with galvanized pressure tanks. Stainless steel tank models may be used with halogenated solvents.

CAUTION

Refer to specifications chart to ensure that fluids and solvents being used are chemically compatible with the tank wetted parts. Before placing fluids or solvents in tank, always read accompanying manufacturer's literature.

Standard Fluid Regulated Tanks (Single Regulation)

Standard type tank for use on jobs where precision control of both fluid and atomization air pressures is not required. Also used where atomization air can be taken from filter/regulator air lines. Provides standard fluid pressure control only. Equipped with pressure regulator, pressure gauge, air bleed down valve, safety valve, and inlet and outlet air valves. (For conversion to double regulation, use kit QMS-436.)

Standard Air and Fluid Regulated Tanks (Dual Regulation)

Precision controlled tanks for use with materials that are best applied at low, closely controlled, fluid and atomization air pressures. Used with portable air compressors or with air lines when no other means of air pressure regulation (filter/regulator) is available. Equipped with two regulators (one for fluid pressure, the other for atomization air pressure), two pressure gauges, air bleed down valve, safety valve, and inlet and outlet valves.

Agitation

Pressure tanks can be equipped with different types of fluid agitation, or no agitation.

WARNING

Air pressure loads that are higher than design loads, or changes to the pressure feed tank, can cause the tank to rupture or explode.

- A safety valve protects the tank from overpressurization. During each use, pull ring on the safety valve to make sure it operates freely and relieves air pressure. If the valve is stuck, does not operate freely, or does not relieve air pressure, it must be replaced with a safety valve having the same rating. Do not eliminate, make adjustments to, or substitute this valve.
- Changes to the air tank will weaken it. Never drill into, weld, or change the tank in any way.
- Maximum working pressure of this tank is 110 psi.

WARNING

Static electricity is created by the flow of fluid through the pressure tank and hose. If all parts are not properly grounded, sparking may occur. Sparks can ignite vapors from solvents and the fluid being sprayed.

If static sparking, or slight shock, is experienced while using this equipment, stop spraying immediately.

Ground the pressure tank by connecting one end of a 12 gauge minimum ground wire to the pressure tank and the other end to a true earth ground. Local codes may have additional grounding requirements. See illustration, page 5, for grounding and grounding hardware required.

Note

(For non-direct drive models)

A tank with agitator assembly is shipped with the curved edge of the paddle down. When a steel insert container is used it is necessary to turn the bottom paddle upside down so that the flat side is down. In either position, the correct adjustment on the paddle position is with the end of the paddle hub flush with end of the shaft. This mounting should give 1/2 inch clearance between the edge of the paddle and the insert container.

WARNING

Pressure Relief Procedure

High pressure can cause a serious injury. Pressure is maintained in a pressure tank after the system has been shut down. Before attempting removal of fill plug or cover, pressure must be relieved using the following steps:

1. Turn off the main air supply to the tank.
2. Close air inlet valve located on tank air manifold.
3. Bleed off air in the tank by turning the air relief valve thumb screw counterclockwise. Wait until all the air has escaped through the valve before removing the pressure tank cover or fill plug.

(Continued on page 4)

SAFETY PRECAUTIONS

This manual contains important information that all users should know and understand before using the equipment. This information relates to USER SAFETY and PREVENTING EQUIPMENT PROBLEMS. To help you recognize this information, we use the following terms to draw your attention to certain equipment labels and portions of this Service Bulletin. Please pay special attention to any label or information that is highlighted by one of these terms:



Important information to alert you to a situation that might cause serious injury if instructions are not followed.







Important information that tells how to prevent damage to equipment, or how to avoid a situation that might cause minor injury.

Note

Information that you should pay special attention to.

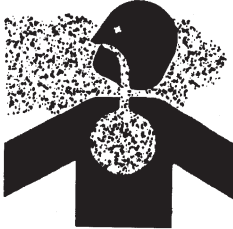

The following hazards may occur during the normal use of this equipment. Please read the following chart.

HAZARD	CAUSE	SAFEGUARDS
Fire 	Solvents and coatings can be highly flammable or combustible, especially when sprayed.	<ol style="list-style-type: none"> 1. Adequate exhaust must be provided to keep the air free of accumulations of flammable vapors. 2. Smoking must never be allowed in the spray area. 3. Fire extinguishing equipment must be present in the spray area.
Fire - Pressure Tank 	Vapors from flammable liquids can catch fire or explode.	<ol style="list-style-type: none"> 1. Keep tank at least 10 feet away from sources of ignition. Ignition sources include hot objects, mechanical sparks, and arcing (non-explosion proof) electrical equipment.
Inhaling Toxic Substances 	Certain materials may be harmful if inhaled, or if there is contact with the skin.	<ol style="list-style-type: none"> 1. Follow the requirements of the Material Safety Data Sheet supplied by your coating material manufacturer. 2. Adequate exhaust must be provided to keep the air free of accumulations of toxic materials. 3. Use a mask or respirator whenever there is a chance of inhaling sprayed materials. The mask must be compatible with the material being sprayed and its concentration. Equipment must be as prescribed by an industrial hygienist or safety expert, and be NIOSH approved.
Explosion, Pressure Tank - Rupture 	Making changes to pressure tank will weaken it.	<ol style="list-style-type: none"> 1. Never drill into, weld, or modify tank in any way. 2. Do not adjust, remove, or tamper with the safety valve. If replacement is necessary, use the same type and rating of valve.
General Safety	Improper operation or maintenance may create a hazard.	Operators should be given adequate training in the safe use and maintenance of the equipment (in accordance with the requirements of NFPA-33, Chapter 15 in U.S.). Users must comply with all local and national codes of practice and insurance company requirements governing ventilation, fire precautions, operation, maintenance and housekeeping (in the U.S., these are OSHA Sections 1910.94 and 1910.107, and NFPA-33).

TO ASSEMBLE REGULATORS AND HOSE TO TANK

GALVANIZED MODELS		
9.8 GAL 83G	Air Regulation	Fluid Agitation*
83G-510	Single Reg.	No Agitation
83G-520	Double Reg.	No Agitation
83G-513 (I)	Single Reg.	Std. Agitation
83G-523 (I)	Double Reg	Std. Agitation
83G-516 (R)	Single Reg	Opt. Agitation
STAINLESS MODELS		
9.8 GAL 83S	Air Regulation	Fluid Agitation*
83S-500 (A)	None	None
83S-510	Single Reg	No Agitation
83S-520	Double Reg	No Agitation
83S-513 (I)	Single Reg	Std. Agitation
83S-523 (I)	Double Reg	Std. Agitation
83S-533 (I)	Extra-Sensitive	Std. Agitation
83S-516 (R)	Single Reg	Opt. Agitation
83S-526 (R)	Double Reg	Opt. Agitation

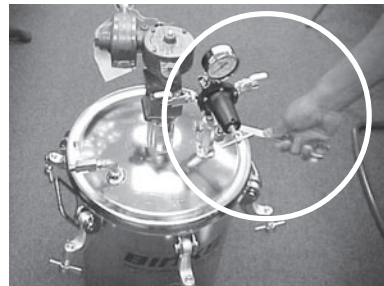

Assemble single regulator to manifold using an 11/16 wrench.

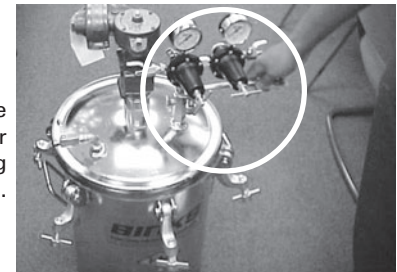

Assemble double regulator to manifold using an 11/16 wrench.

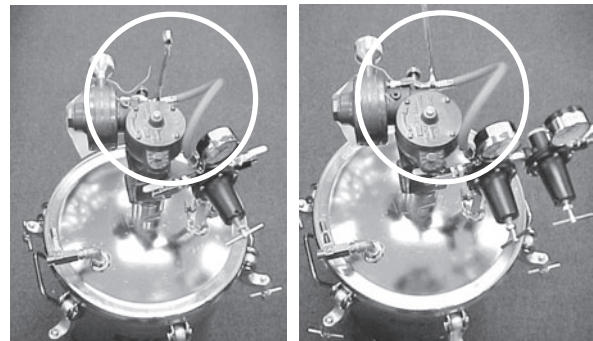

Assemble hose to either manifold using a 5/8 wrench.

- *(A)= No air regulation/no agitation. Uses QMS-4003 No Regulation Kit for air connection.
- *(I)= Indirect Drive Agitator: Air Motor coupled to gearbox for higher torque at lower speeds.
- *(R)= Reciprocating Agitator: Self-Reversing Air Motor for efficient mixing and reduced cavitation.

SPECIFICATION CHART

	(Galvanized Models)	(Stainless Steel Models)
Maximum Working Pressure	110 PSI	110 PSI
Tank Shell	SA-414 H.R. Steel Zinc Plate 12 gauge (0.105 in.) thick	304 Stainless Steel, 13 gauge (.0897 in.) thick
Tank Lid	SA-414 H.R. Steel Zinc Plate 3/16 in. thick	304 Stainless Steel, 3/16 in. thick
Agitator Shaft	CRS Zinc Plate	303 Stainless Steel
Fluid Tube	Galvanized Zinc Plate, 3/8 in. pipe	316 Stainless Steel, 3/8 in. pipe
Fluid Valve, Outlet	Brass 3/8-18 NPSM outlet	316 Stainless Steel, 3/8-18 NPSM outlet,
Air Manifold	CRS Zinc plated	CRS Zinc plated
Shaft Seal	Engineered Teflon, Stainless Steel	Engineered Teflon, Stainless Steel
Agitator Paddles	Nylon, Glass Filled	Nylon, Glass Filled
Fluid Outlet	Galvanized Steel Zinc Plate	316 Stainless Steel
Bottom Outlet (Optional Kit) (QMS-443)	304 Stainless Steel, 3/4 in. NPSM Valve	304 Stainless Steel, 3/4 in. NPSM outlet

DIMENSIONS

TANK SIZE	INSIDE DIAMETER (Inches)	INSIDE HEIGHT AT CENTER (Inches)	OVERALL HEIGHT* (Inches)	OVERALL WIDTH (Inches)	WEIGHT* (Pounds)
9.8 Gallon	14	16	20-5/16	18-1/2	64 (Galvanized) 51 (Stainless Steel)

*Basic tank, not including regulators or agitation.

4. Leave the air relief valve open until you have reinstalled the cover or fill plug.

Mix and prepare material to be used according to manufacturer's instructions. Strain material through a fine mesh screen to remove lumps, skin, and foreign matter that might enter and clog fluid passages and/or spray equipment.

1. Follow pressure relief procedures listed on page 1.
2. To add material to tank, remove lid and pour directly into the tank or container.

Note

If desired, a U.S. or metric 5 gallon pail of fluid can be placed directly into the tank.

3. Replace the lid assembly and tighten thumb screws (6) securely.
4. The air supply to the tank should be filtered to remove dirt, water and oil. Connect the air supply line to the tank inlet valve.
5. Connect the material hose to fluid outlet ball valve (16).

USING BOTTOM OUTLET PORT

The pressure tank has a 1 inch NPT drain port in the bottom of the tank. Bottom outlet kits may be connected into the drain port. Use bottom outlet feature when top outlet is not desirable.

OPERATION

1. Close air inlet valve to tank. Turn handle on regulator counterclockwise until spring tension is relieved.
2. Turn on air supply to tank.
3. Open air inlet valve to tank.
4. Open fluid outlet valve.
5. Turn handle on tank pressure regulator clockwise to pressurize tank. Clockwise increases material pressure; counterclockwise will decrease material pressure.
6. Turn on atomization air to spray gun at source of supply.
7. Test spray. For further instructions, see spray gun Service Bulletin SB-2-001.
8. If an air motor drive is used, start the agitator by slowly opening the needle valve. Air motor speed should be regulated according to the nature of the material being agitated.

PREVENTIVE MAINTENANCE

To clean equipment, proceed as follows:

1. Turn off the air supply.
2. Follow pressure relief procedure on page 1.
3. Turn T-handle adjusting screw on tank fluid regulator counterclockwise until no spring pressure is felt.

4. Loosen thumb screws (6), tip clamps (7) back, and tip lid (15) to one side of tank. Do not remove lid from tank.
5. Loosen spray gun air cap retaining ring about three turns.
6. Turn on air supply.
7. Cup cloth over air cap on the gun and pull trigger. This will force material back through the hose, into the tank.
8. Empty and clean tank and parts that come into contact with material. Use a solvent compatible with material being used.
9. Pour solvent into tank.
10. Replace lid and tighten thumb screws and clamps.
11. Spray until clean solvent appears.
12. Repeat steps 4 through 8.

LUBRICATION

Refer to the service manual provided with the agitator air motor for lubrication information.

The bearings in the agitator bearing assembly are impregnated with a special non-gumming oil. Therefore, additional lubrication is not required.

The agitator shaft seal does not require lubrication.

SERVICE CHECKS

CONDITION	CAUSE	CORRECTION
A. Air escaping from port on regulator cap.	1. Broken or damaged diaphragm.	1. Replace diaphragm.
B. Pressure creepage registered on gauge.	1. Dirty or worn valve seat in regulator.	1. Clean or replace valve seat.
C. Material tends to settle out rapidly.	1. Not enough agitation of material.	1. Increase agitation.
D. Air leakage at agitator seal.	1. Worn seal assembly.	1. Replace.
E. Paint getting into bearing assembly of agitator.	1. Paint level in tank too high. 2. Worn agitator shaft seal.	1. Do not fill tank above agitator bearing assembly. 2. Replace.
F. Fluid or air leak at lid gasket.	1. Thumb screw not tight. 2. Defective lid gasket.	1. Tighten. 2. Replace.
G. Air mixing with paint.	1. Fluid tube not sealed to lid. 2. Excessive agitation.	1. Tighten fluid tube into lid. 2. Reduce speed of agitator.

NOTE: Occasionally check pressure gauge. The needle should return to zero with no pressure on the gauge.

Note

Use a Teflon based sealant on all air/fluid connections.

9.8 Gallon Tank Exploded View

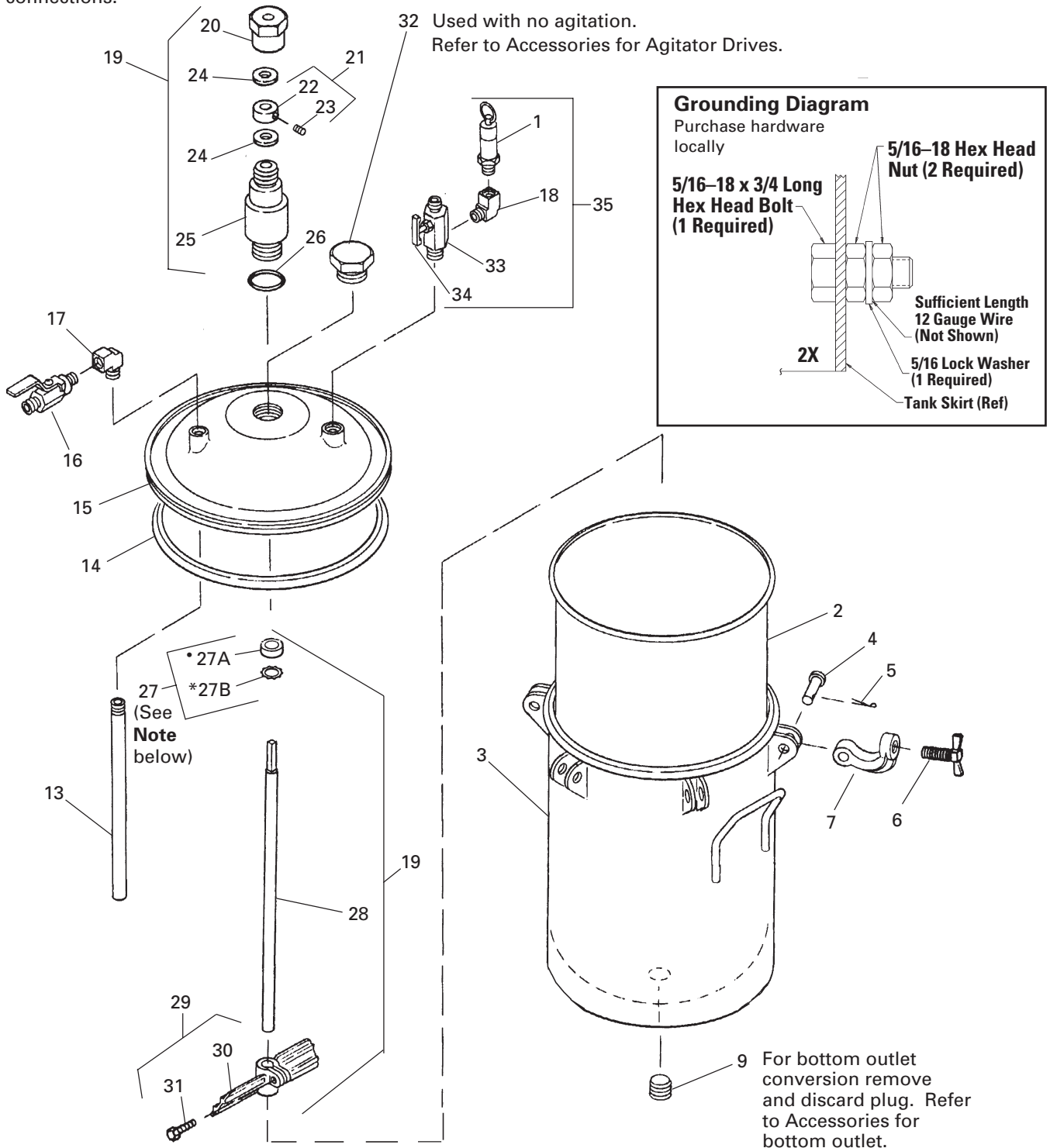

Note

• Open side of Shaft Seal (27A) faces downward.

* Retainer 27B only required in tank if used for vacuum operation. Not necessary to replace if tank is used for pressure only.

PARTS LIST

REF NO.	REPLACEMENT PART NO. 9.8 GAL. GALVANIZED	REPLACEMENT PART NO. 9.8 GAL. STAINLESS STEEL	DESCRIPTION	INDIVIDUAL PARTS REQ.
1	TIA-5110	Same	Safety Valve Assembly, 110 psi	1
2	PTL-408-K20	Same	Disposable Polyethylene Tank Liner	1
3	QMG-505	QMS-505	Tank Assembly	
+4	---	---	Clevis Pin	6
+5	---	---	Cotter Pin (1/8 dia. x 1 in. long)	6
+6	QM-1352	Same	Thumb Screw	6
+7	---	---	Clamp	6
8	Not Used	Not Used	---	
9	---	---	Plug	1
10	Not Used	Not Used	---	
11	Not Used	Not Used	---	
12	Not Used	Not Used	---	
13	QMG-32	QMS-10-1	Fluid Tube (3/8"-18 NPT)	1
14	QM-1458-1	Same	Lid Gasket, Santoprene	1
15	QMG-402	QMS-417	Tank Lid	1
16	VA-540	VA-527	Ball Valve	1
•17	---	SSP-1939	Street Elbow (3/8"-18 NPT)	1
•18	---	---	Street Elbow (1/4"-18 NPT Brass)	1
19	QMG-418	QMS-432	Agitator Assembly (includes items 20 through 31)	1
20	QMS-46	Same	Retaining Nut	1
21	QMS-447	Same	Thrust Collar Kit (includes items 22 and 23)	1
22	---	---	Thrust Collar	1
•23	---	---	Setscrew (5/16-18 x 3/8)	1
24	KK-5049	Same	Thrust Washer Kit (includes 2 washers)	1
25	QMG-409	QMS-407	Bearing Assembly	1
26	SSG-8184-K2	Same	O-Ring (Kit of 2)	1
27	KK-5042	Same	Shaft Seal Kit	2
27A	---	---	Shaft Seal	1
27B	---	---	Retainer	1
28	QMG-28	QMS-6	Agitator Shaft (5/8" Dia.)	1
29	QMS-444	Same	Agitator Paddle Kit (includes items 30 and 31), Nylon	1
30	---	---	Agitator Paddle	1
•31	---	---	Hex Socket Head Cap Screw (5/16-18 x 1-1/4, Stainless Steel)	1
32	QMG-19	QMS-3	Plug	1
33	QMG-21	Same	Air Manifold	1
34	SS-2707	Same	Air Relief Valve	1
*35	KK-5077	Same	Air Manifold Kit	1

- Purchase locally.
- + KK-5014 Clamp, Pin and Screw Kit includes 1 each of Items 4, 5, 6 and 7.
- * Not sold by ITW Industrial Finishing—order individual items 1, 18, 33 or 34.

ACCESSORIES

QMS-443 BOTTOM OUTLET CONVERSION KIT

Fittings that allow standard top outlet tank to feed from bottom by removing plug in bottom port. Kit includes stainless steel shutoff valve and all stainless steel parts.

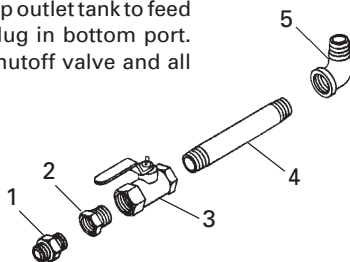

Ref No.	Replacement Part No.	Description	Qty.
1	---	Adapter, 3/4" NPT to 3/4-14 NPS(M)	1
2	---	Reducer Bushing, 3/4 to 1" Stainless Steel	1
3	---	Ball Valve, 1 x 1 NPT(F) Stainless Steel 150 PSI	1
4	---	Pipe Nipple (1" s.s.)	1
5	---	Street Elbow (1" Stainless Steel)	1

ACCESSORIES (CONTINUED)

QMS-4006 SINGLE REGULATOR KIT (STANDARD)

Provides standard fluid pressure control only. For use when atomization air is controlled by a separate filter-regulator. Kit includes pressure regulator with gauge, inlet and outlet shutoff valves, and connection fittings. Refer to 77-2781 for regulator service parts.

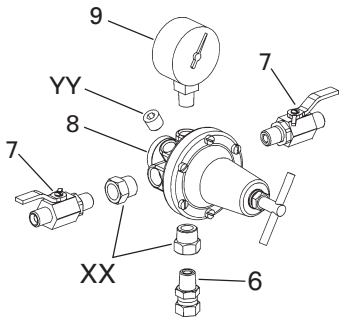

Ref No.	Replacement Part No.	Description	Qty
6	SSP-8217-ZN	Swivel Adapter	1
7	VA-542	Valve	2
8	HAR-511	Regulator	1
9	83-1290	Gauge, 150 lbs.	1
•XX	----	Bushing, 3/8(m) x 1/4 (f) (Supplied/Regulator)	2
•YY	----	Pipe Plug, 1/4 NPT (Supplied/Reg)	1

•Purchase locally.

QMS-4007 DUAL REGULATOR KIT (STANDARD)

Provides independent controls for fluid pressure in tank and atomization air pressure. Kit includes two regulators with gauges, inlet and outlet shutoff valves, and connection fittings. Refer to SBBI-6-147 and 77-2781 for regulator service parts.

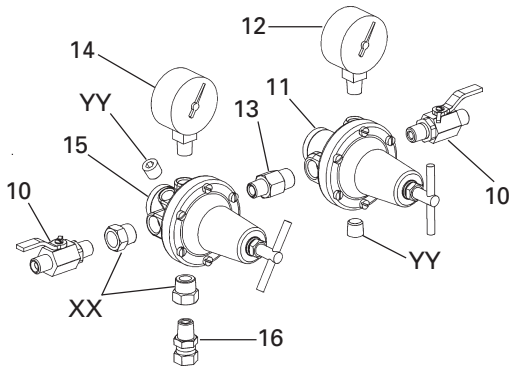

Ref No.	Replacement Part No.	Description	Qty
10	VA-542	Valve	2
11	HAR-507	Regulator	1
12	83-1355	Gauge, 100 lbs.	1
13	83-4233	D.M. Nipple, 1/4 x 3/8 Universal Pipe Thread	1
14	83-1290	Gauge, 150 lbs.	1
15	HAR-511	Regulator	1
16	SSP-8217-ZN	Swivel Adapter	1
•XX	----	Bushing, 3/8(m) x 1/4 (f) (Supplied/Regulator)	2
•YY	----	Pipe Plug, 1/4 NPT (Supplied/Reg)	2

•Purchase locally.

QMS-4010 EXTRA SENSITIVE REGULATOR KIT

Use with electrostatic spray or other applications requiring extremely sensitive nonfluctuating low pressure control. Kit includes one extra sensitive gauge, one extra sensitive regulator, inlet and outlet shutoff valves, and connection fittings. Refer to SBBI-6-131 for regulator service parts.

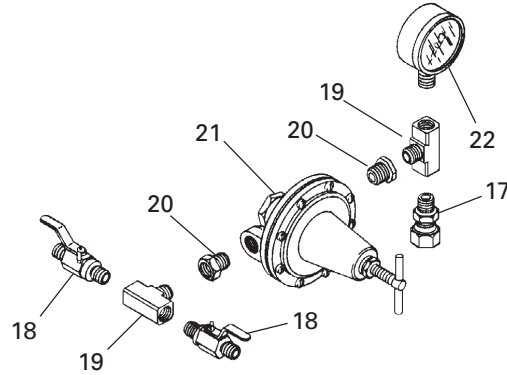

Ref No.	Replacement Part No.	Description	Qty.
17	SSP-8217-ZN	Swivel Adapter	1
18	VA-542	Valve	2
19	SSP-2629-ZN	Tee Male Branch	2
20•	----	Hex Reducer Bushing (3/8 x 1/4 Galvanized)	2
21	HAR-501	Extra Sensitive Regulator	1
22	83-1414	Gauge 30 lb	1

•Purchase locally.

QMS-436 CONVERSION TO DOUBLE REGULATOR ASSEMBLY KIT

Adapts to tanks equipped with single regulator to provide independent pressure control of atomization air and fluid pressures. Converts QMS-4006 single regulator to a QMS-4007 dual regulator. Refer to SBBI-6-147 for regulator service parts.

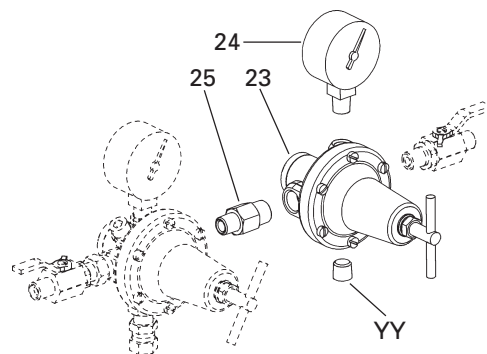

Ref No.	Replacement Part No.	Description	Qty
23	HAR-507	Regulator	1
24	83-1355	Gauge, 100 lbs.	1
25	83-4233	D.M. Nipple, 1/4 x 3/8 Universal Pipe Thread	1
•YY	----	Pipe Plug, 1/4 NPT (Supplied/Reg)	1

•Purchase locally.

ACCESSORIES (CONTINUED)

QMS-4003 NO REGULATION KIT

Use when fluid pressure in tank is regulated by some other separate controls. Kit includes air shutoff valve, gauge to read fluid pressure in tank, and fittings.

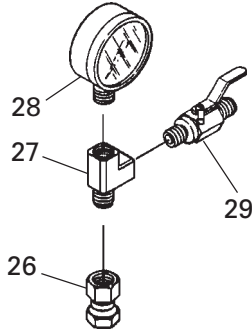

Ref No.	Replacement Part No.	Description	Qty
26•	----	Swivel Coupling 1/4 NPS(M) x 1/4 NPT(F)	1
27•	----	Street Tee (1/4")	1
28	83-1290	Gauge 150 lb	1
29	VA-542	Valve	1

•Purchase locally.

VS-534 FLUID STRAINER

Primary fluid strainer that attaches between fluid outlet valve and fluid hose to strain material. Components made of stainless steel with nylon filter. Comes standard with 100-mesh screen. For more information see SBBI-7-072.



HFRL-508, HFRL-509 CLEAN AIR™ CONTROL UNITS

These units are designed to remove dirt, pipe scale and most liquid aerosol. Includes an automatic drain which expels liquids which accumulate in the filter bowl.

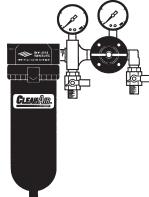

WARRANTY

This product is covered by Binks' 1 Year Limited Warranty.

Binks Worldwide Sales and Service Listing: www.binks.com

ITW Industrial Finishing

Binks has authorized distributors throughout the world. For technical assistance or the distributor nearest you, see listing below.

U.S./Canada Technical Service Office:

195 Internationale Blvd., Glendale Heights, IL 60139
Toll-Free Telephone: 1-888-992-4657 (U.S.A. and Canada only)
Toll-Free Fax: 1-888-246-5732

QS-5012 INDIRECT AGITATOR DRIVE

Standard duty 1/2 hp agitator drive with 15:1 gear reduction. Operates from 20 to 120 rpm. Mounts on agitator shaft. Includes throttling valve, fittings, and hose for connection to air supply on tank lid. For further information see SBBI-19-087.

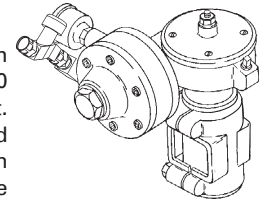

31-381 OSCILLATING AIR MOTOR

Low air consumption motor mounts easily on tanks equipped for material agitation. Slow back and forth motion ensures proper agitation. Operates at 10 to 30 cycles per minute. For more information see Part Sheet 77-2788.

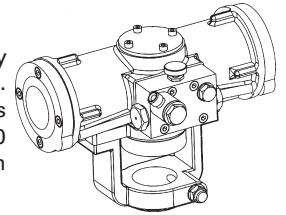

DISPOSABLE TANK LINERS

Molded polyethylene tank liners to reduce solvent waste and tank cleanup time. The liner is made of tough, durable, leakproof polyethylene and can be used with all compatible materials.

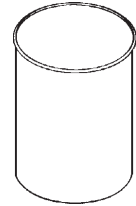

PTL-408-K20 Kit of 20 tank liners for 9.8 Gal.

SCRUBS® HAND CLEANER TOWELS

Scrubs® are a pre-moistened hand cleaner towel for painters. No water is needed.

29-3100 ITW Industrial Finishing
192218 ITW Automotive Refinishing



PROSPECTOR PAINT STRAINERS

A convenient way to strain paint while filling pressure tank.

PTS-5 GAL-K20-200 (200 micron)
PTS-5 GAL-K20-400 (400 micron)
PTS-5 GAL-K20-600 (600 micron)

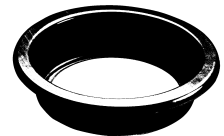

An Illinois Tool Works Company

ITW Automotive Refinishing

Binks has authorized distributors throughout the world. For equipment, parts and service, check the Yellow Pages under "Automotive Body Shop Equipment and Supplies." For technical assistance, see listing below.

U.S./Canada Customer Service Office:

1724 Indian Wood Circle, Suite J-K, Maumee, OH 43537
Toll-Free Telephone: 1-800-445-3988 (U.S.A. and Canada only)
Toll-Free Fax: 1-800-445-6643